

SMART OPERATING OF HOME LIGHTNING WITH ZIGBEE COMMUNICATIONS

B.ASHWINI¹, K. SRINIVASA REDDY² (Guide & Assoc. Professor)

^{1,2}Electronics and Communication Engineering
SR Engineering College
Warangal, India

ABSTRACT: There are many types of illumination equipment in a home or building, like incandescence, fluorescent and led lamps. There are different ways of controlling their status, schedule and pattern. In past days we control the status, scheduled the loads, controlling the speeds and pattern of the loads instantaneously. i.e., they controlled status or scheduled but not both at a time. So using this system we controlled the status and schedule both at a time. In this system we use ZIGBEE module to control via wireless.

Our design uses a ZIGBEE module which sends the control and sensing signals between the units, and also ZIGBEE has the advantage it can increase the number of nodes up to 255 under the MASH protocol. This suffices for lighting control in the home more over each ZIGBEE sensor node has a unique id for transmitting information.

In this project we control the switching of loads in home via wireless using ZIGBEE. And also we control the status of the loads, control the loads by scheduled using RTC. And also we control the patterns of loads and we control the speed of the load. While controlling the loads we can check the status of those loads.

Keywords- ARM, Zigbee, Driver unit, LCD, Potential meter.

I. INTRODUCTION

block diagram:

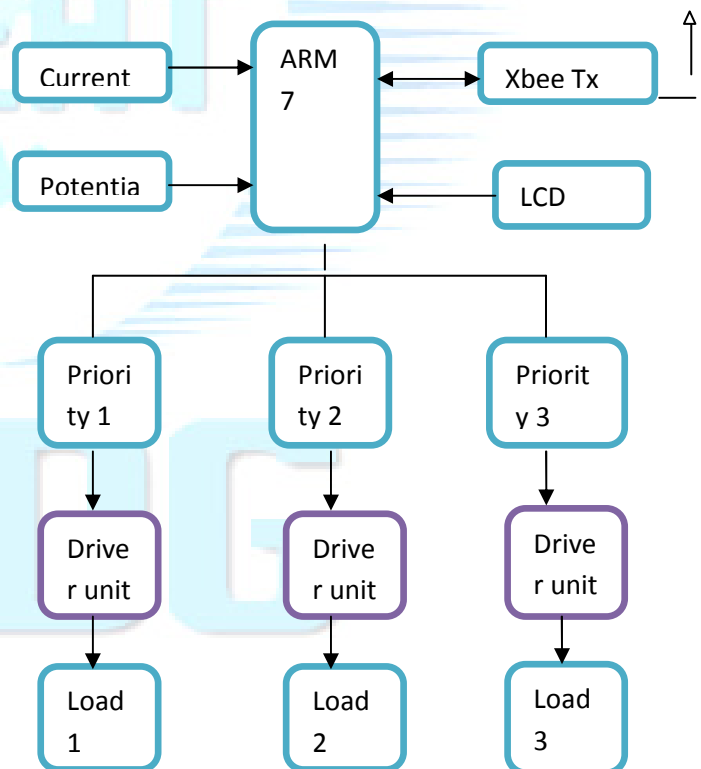

Fig:I Distributionmanagement system

EB Section:

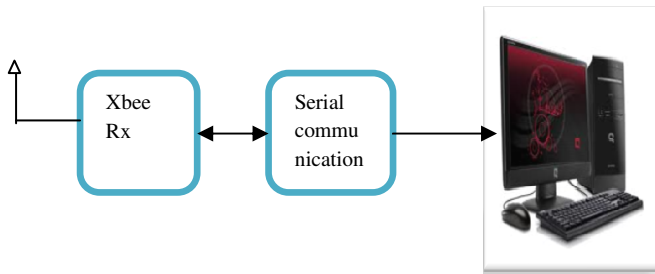

Fig: II Control Room section.

II. ARM7 TDMI-S Description:

A).Micro Controller (ARM7) FAMILY

The ARM7 family includes the ARM7TDMI, ARM7TDMI-S, ARM720T, and ARM7EJ-S processors. The ARM7TDMI core is the industry's most widely used 32-bit embedded RISC microprocessor solution. Optimized for cost and power-sensitive applications, the ARM7TDMI solution provides the low power consumption, small size, and high performance needed in portable, embedded applications.

The ARM7TDMI-S core is the synthesizable version of the ARM7TDMI core, available in both VERILOG and VHDL, ready for compilation into processes supported by in-house or commercially available synthesis libraries. Optimized for flexibility and featuring an identical feature set to the hard macro cell, it improves time-to-market by reducing development time while allowing for increased design flexibility, and enabling >>98% fault coverage. The ARM720T hard macro cell contains the ARM7TDMI core, 8kb unified

cache, and a Memory Management Unit (MMU) that allows the use of protected execution spaces and virtual memory. This macro cell is compatible with leading operating systems including Windows CE, Linux, palm OS, and SYMBIAN OS.

The ARM7EJ-S processor is a synthesizable core that provides all the benefits of the ARM7TDMI – low power consumption, small size, and the thumb instruction set – while also incorporating ARM's latest DSP extensions and Jazelle technology, enabling acceleration of java-based applications. Compatible with the ARM9™, ARM9E™, and ARM10™ families, and Strong-Arm® architecture software written for the ARM7TDMI processor is 100% binary-compatible with other members of the ARM7 family and forwards-compatible with the ARM9, ARM9E, and ARM10 families, as well as products in Intel's Strong ARM and xscale architectures. This gives designers a choice of software-compatible processors with strong price-performance points. Support for the ARM architecture today includes:

- Operating systems such as Windows CE, Linux, palm OS and SYMBIAN OS.
- More than 40 real-time operating systems, including qnx, wind river's vx works.

B).LPC2148 MICROCONTROLLER

LPC2148 Microcontroller Architecture. The ARM7TDMI-S is a general purpose 32-bit

III. TRANSFORMERS

A).POTENTIAL TRANSFORMERS:

PTs or VTs are the most common devices used. These devices are conventional transformers with two or three windings (one primary with one or two secondary). They have an iron core and magnetically couple the primary and secondary. The high side winding is constructed with more copper turns than the secondary (ies), and any voltage impressed on the primary winding is reflected on the secondary windings in direct proportion to the turns ratio or PT ratio.

Sometimes called as voltage transformers - used for line and circuit protections.

The turns ratio described above is backwards: There is a large number of primary turns and only few secondary turns so that the voltage is stepped down from the high voltage used in a power transmission line to a low voltage actually being measured. For example, 13 kV is stepped down to 5 volts which is then measured using standard instruments.

B) CURRENT TRANSFORMER:

A current transformer (CT) is a type of instrument transformer designed to provide a current in its secondary winding proportional to the alternating current flowing in its primary. They are commonly used in metering and protective relaying in the electrical power

industry where they facilitate the safe measurement of large currents, often in the presence of high voltages. The current transformer safely isolates measurement and control circuitry from the high voltages typically present on the circuit being measured.

The instrument current transformer (CT) steps down the current of a circuit to a lower value and is used in the same types of equipment as a potential transformer. This is done by constructing the secondary coil consisting of many turns of wire, around the primary coil, which contains only a few turns of wire. In this manner, measurements of high values of current can be obtained.

A current transformer should always be short-circuited when not connected to an external load. Because the magnetic circuit of a current transformer is designed for low magnetizing current when under load, this large increase in magnetizing current will build up a large flux in the magnetic circuit and cause the transformer to act as a step-up transformer, inducing an excessively high voltage in the secondary when under no load.

IV. WIRELESS COMMUNICATION

Zigbee module:

The XBee/XBee-PRO RF Modules are designed to operate within the ZigBee protocol

and support the unique needs of low-cost, low-power wireless sensor networks. The modules require minimal power and provide reliable delivery of data between remote devices. The modules operate within the ISM 2.4 GHz frequency band and are compatible with the following:

- XBee RS-232 Adapter
- XBee RS-232 PH (Power Harvester) Adapter
- XBee RS-485 Adapter
- XBee Analog I/O Adapter
- XBee Digital I/O Adapter
- XBee Sensor Adapter
- XBee USB Adapter
- XStick
- Connect Port X Gateways
- XBee Wall Router.

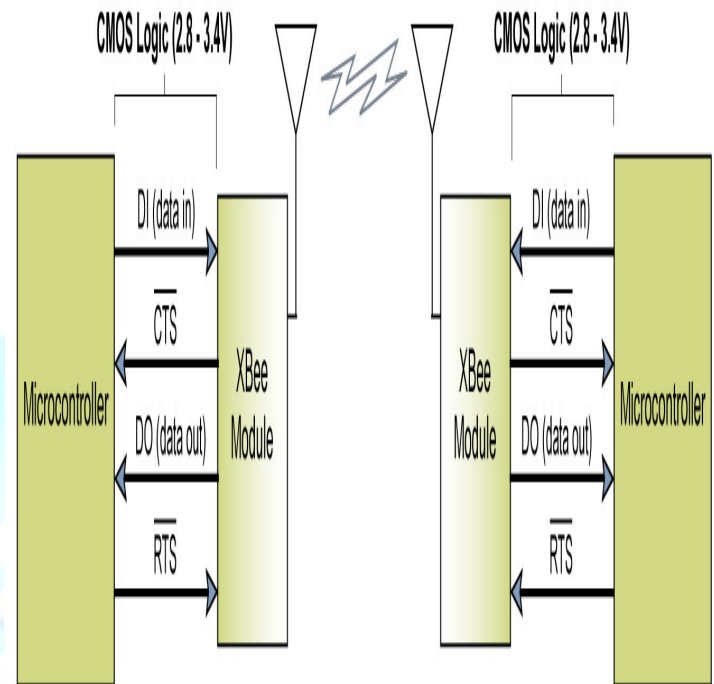

Fig IV: Zigbee module

The XBee/XBee-PRO ZB firmware release can be installed on XBee modules. This firmware is compatible with the ZigBee 2007 specification, while the ZNet 2.5 firmware is based on Ember's proprietary "designed for ZigBee" mesh stack (EmberZNet 2.5). ZB and ZNet 2.5 firmware are similar in nature, but not over-the-air compatible. Devices running ZNet 2.5 firmware cannot talk to devices running the ZB firmware.

V.LCD MODULE(2X 16 CHARACTERS):

Dot matrix LCD modules is used for display the parameters and fault condition.16 characters 2 lines display is used. It has controller which interface data's and LCD panel. Liquid crystal displays (LCD's) have materials, which combine the properties of both liquids and crystals. Rather than having a melting point, they have a temperature range within which the molecules are almost as mobile as they would be in a liquid, but are grouped together in an ordered form similar to a crystal. An LCD consists of two glass panels, with the liquid crystal material sandwiched in between them. The inner surface

of the glass plates are coated with transparent electrodes which define the character, symbols or patterns to be displayed polymeric layers are present in between the electrodes and the liquid crystal molecules to maintain a defined orientation angle

One each polarizer's are pasted outside the two glass panels. These polarizer's would rotate the light rays passing through them to a definite angle, in a particular direction When the LCD is in the off state, light rays are rotated by the two



Figure V – LCD

The LCD's are lightweight with only a few millimeters thickness. since the LCD's consume less power, they are compatible with low power electronic circuits, and can be powered for long durations .The LCD's don't generate light is needed to read the display. By using backlighting, reading is possible in the dark .The LCD's have long life and a wide operating temperature range.

Table 10-2: IBM PC DB-9 Signals

Pin	Description
1	Data carrier detect (DCD)
2	Received data (RxD)
3	Transmitted data (TxD)
4	Data terminal ready (DTR)
5	Signal ground (GND)
6	Data set ready (DSR)
7	Request to send (RTS)
8	Clear to send (CTS)
9	Ring indicator (RI)

One of the most popular output devices for embedded electronics is LCD. The LCD interface has become very simple. This is due to the availability modules for LCDs. The LCD along with necessary controller (LCD Controller) and mounting facility is made available in the module itself. The LCD controller takes care of everything necessary for the LCD. We communicate with the LCD controller with the help of a command set provided by the manufacturer.

ARM Power Supply

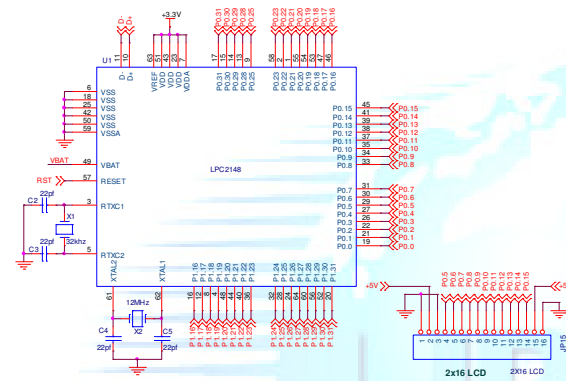
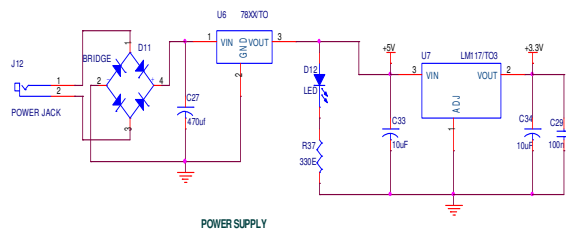

Fig VI: Inter facing LCD with Arm Processor

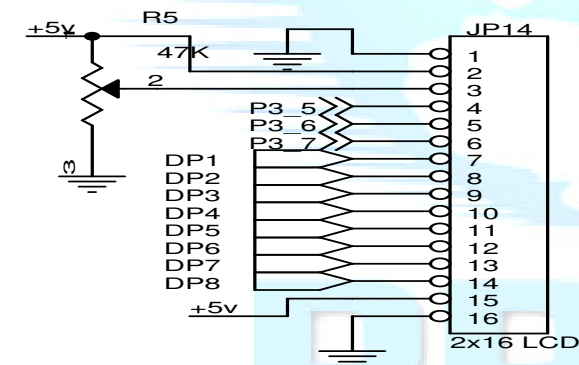

Fig VII: LCD circuit diagram

This circuit consists of a Microcontroller and a LCD. This LCD is operating with an 8-bit data bus. So totally 11 data lines are required (8 Data lines and 3 control lines). The 8 bit data lines are connected to the Port1 and the 3 control lines to the Port3.5-Port3.7. The EN line is called "Enable." This control line indicates to

the LCD that we are sending it data. To send data to the LCD, the EN should be low (0) and then set the other two control lines and/or put data on the data bus. When the other lines are completely ready, bring EN high (1) and wait for the minimum amount of time required by the LCD datasheet (this varies from LCD to LCD), and end by bringing it low (0) again.

The RS line is the "Register Select" line. When RS is low (0), the data is to be treated as a command or special instruction (such as clear screen, position cursor, etc.). When RS is high (1), the data being sent is text data, which should be displayed on the screen. For example, to display the letter "T" on the screen we would set RS high.

The RW line is the "Read/Write" control line. When RW is low (0), the information on the data bus is being written to the LCD. When RW is high (1), the program is effectively querying (or reading) the LCD. Only one instruction ("Get LCD status") is a read command. All others are written commands so RW will almost always be low.

VI. Relay circuit

The coil of a relay passes a relatively large current, typically 30mA for a 12V relay, but it can be as much as 100mA for relays designed to operate from lower voltages. Hence

a CB amplifier is used to achieve the current rating of the relay.

Transistors and ICs must be protected from the brief high voltage produced when a relay coil is switched off. The diagram shows how a signal diode (e.g. 1N4148) is connected 'backwards' across the relay coil to provide this protection. Current flowing through a relay coil creates a magnetic field which collapses suddenly when the current is switched off. The sudden collapse of the magnetic field induces a brief high voltage across the relay coil which is very likely to damage transistors and ICs. The protection diode allows the induced voltage to drive a brief current through the coil (and diode) so the magnetic field dies away quickly rather than instantly. This prevents the induced voltage becoming high enough to cause damage to transistors and ICs.

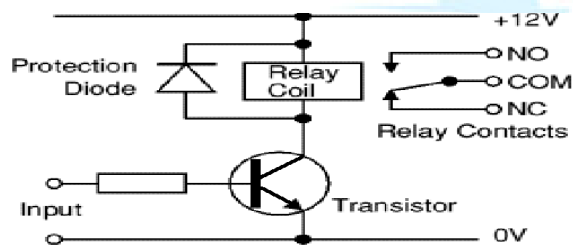
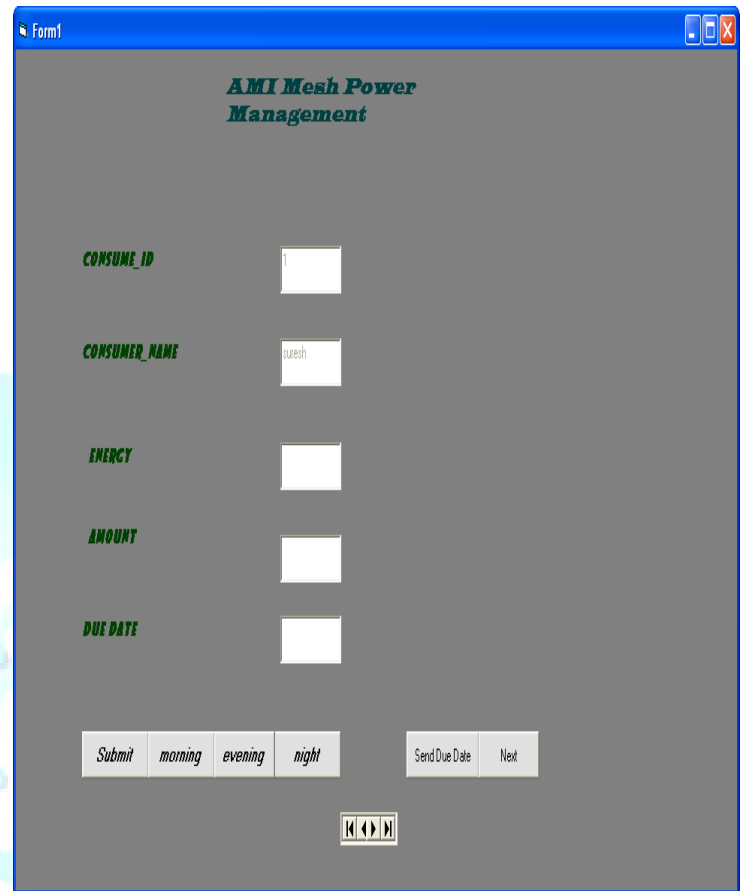

Fig VIII: Relay connection diagram

OUT PUT SCREEN SHOTS



VIII.Conclusion

By using this project Government providing the supply according to priority due to this the usage of supply will be utilizing on priority. According to this project mainly we are doing the three concepts 1.Power meter reading 2.Power Management 3.Power theft.

In this paper, we propose an intelligent energy management system (iEDM). The concept of dynamic assignment of priorities for all the consumer is established in this project. Slicing of interrupt timings is also discussed which can be used to improve the performance .According to the generated power amount,

power shut down will be announced and it will reach the consumer in the uniform level based on priorities.

IX. Reference

[1] E. Sato, T. Yamaguchi, and F. Harashima, "Natural interface using pointing behavior for human-robot gestural interaction," *IEEE Trans. Ind. Electron.*, vol. 54, no. 2, pp. 1105-1112, Apr. 2007.

[2] Y. S. Kim, B. S. Soh, and S.-G. Lee, "A new wearable input device: SCURRY," *IEEE Trans. Ind. Electron.*, vol. 52, no. 6, pp. 1490-1499, Dec. 2005.

[3] A. D. Cheok, Y. Qiu, K. Xu, and K. G. Kumar, "Combined wireless hardware and real-time computer vision interface for tangible mixed reality," *IEEE Trans. Ind. Electron.*, vol. 54, no. 4, pp. 2174-2189, Aug. 2007.

[4] Z. Dong, U. C. Wejinya, and W. J. Li, "An optical-tracking calibration method for MEMS-based digital writing instrument," *IEEE Sens. J.*, vol. 10, no. 10, pp. 1543-1551, Oct. 2010.

[5] J. S. Wang, Y. L. Hsu, and J. N. Liu, "An inertial-measurement-unit-based pen with a trajectory reconstruction algorithm and its applications," *IEEE Trans. Ind. Electron.*, vol. 57, no. 10, pp. 3508-3521, Oct. 2010.

[6] S.-H. P. Won, W. W. Melek, and F. Golnaraghi, "A Kalman/particle filter-based position and orientation estimation method using a position sensor/inertial measurement unit hybrid system," *IEEE Trans. Ind. Electron.*, vol. 57, no. 5, pp. 1787-1798, May 2010.

[7] S.-H. P. Won, F. Golnaraghi, and W. W. Melek, "A fastening tool tracking system using an IMU and a position sensor with Kalman filters and a fuzzy expert system," *IEEE Trans. Ind. Electron.*, vol. 56, no. 5, pp. 1782-1792, May 2009.

[8] Y. S. Suh, "Attitude estimation by multiple-mode Kalman filters," *IEEE Trans. Ind. Electron.*, vol. 53, no. 4, pp. 1386-1389, Jun. 2006.

[9] J. Yang, W. Chang, W. C. Bang, E. S. Choi, K. H. Kang, S. J. Cho, and D. Y. Kim, "Analysis and compensation of errors in the input device based on inertial sensors," in *Proc. IEEE Int. Conf. Inf. Technol.—Coding and Computing*, 2004, pp. 790-796.

[10] Y. Luo, C. C. Tsang, G. Zhang, Z. Dong, G. Shi, S. Y. Kwok, W. J. Li, P. H. W. Leong, and M. Y. Wong, "An attitude compensation technique for a MEMS motion sensor based digital writing instrument," in *Proc. IEEE Int. Conf. Nano/Micro Eng. Mol. Syst.*, 2006, pp. 909-914.

[11] Z. Dong, G. Zhang, Y. Luo, C. C. Tsang, G. Shi, S. Y. Kwok, W. J. Li, P. H. W. Leong, and M. Y. Wong, "A calibration method for MEMS inertial sensors based on optical tracking," in *Proc. IEEE Int. Conf. Nano/Micro Eng. Mol. Syst.*, 2007, pp. 542–547.

[12] J. G. Lim, S. Y. Kim, and D. S. Kwon, "Pattern recognition-based realtime end point detection specialized for accelerometer signal," in *Proc. IEEE/ASME Int. Conf. Adv. Intell. Mechatron.*, 2009, pp. 203–208.

[13] S. D. Choi, A. S. Lee, and S. Y. Lee, "On-line handwritten character recognition with 3D accelerometer," in *Proc. IEEE Int. Conf. Inf. Acquisition*, 2006, pp. 845–850.

[14] N. C. Krishnan, C. Juillard, D. Colbry, and S. Panchanathan, "Recognition of hand movements using wearable accelerometers," *J. Ambient Intell. Smart Environ.*, vol. 1, no. 2, pp. 143–155, Apr. 2009.

[15] B. Milner, "Probabilistic neural networks," in *Proc. Inst. Elect. Eng.—Colloq. Doc. Image Process. Multimedia*, 1999, pp. 5/1–5/6.